

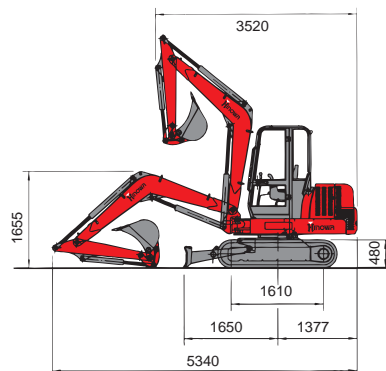

VT 4000

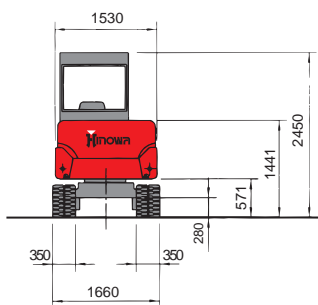

		A	B	C	D	E
	STANDARD L = 1.300 MM	5.145	3.565	3.275	5.475	2.495
	OPTIONAL L = 1.600 MM	5.330	3.750	3.570	5.750	2.750

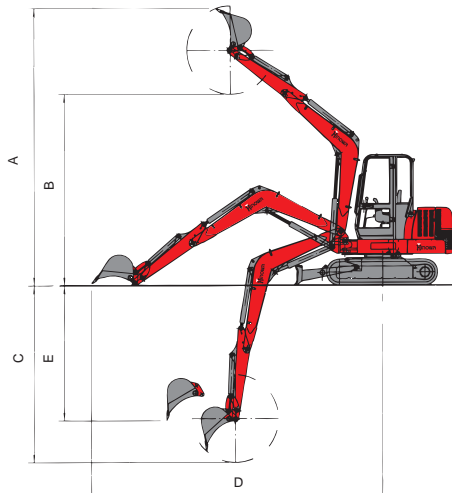
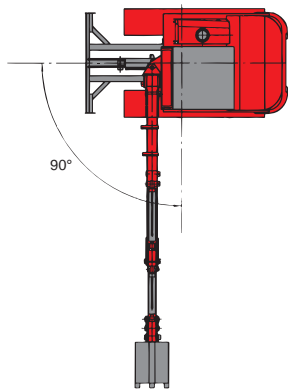

MOTORE ENGINE

Motore diesel
 Marca e tipo Perkins 104.19
 Cilindri e cilindrata 4 / 1995 cc
 Potenza lorda max 42,5 HP (KW 34)
 Avviamento elettrico 12 Volt

Diesel engine
 Brand and model Perkins 104.19
 No. cylinders / cubic displacement 4 / 1995 cc
 Max power 42,5 HP (KW 34)
 Electric starting 12 Volt

IMPIANTO IDRAULICO HYDRAULIC SYSTEM

Pompe: numero e tipo 2 Pv+1 ad ingranaggi
 Portata l/1' 44x2+25x1
 Pressione bar 210

Pumps: No. and type 2 var. displ. + 1 gears
 Capacity l/1' 44x2+25x1
 Pressure bar 210

CARRO UNDERCARRIAGE

Tendingolo a grasso, riduttori epicicloidali con motori a pistoni assiali con doppia cilindrata.
 Larghezza cingolo in gomma mm 350
 Rulli di sostegno per lato 5 + 1
 Doppia Velocità di traslazione Km/h 2.5/4.5
 Larghezza carro mm 1660

Track tension by grease, planetary gear-box with axial pistons motors with double displacement.
 Rubber track width mm 350
 No. rollers per side 5 + 1
 Speed of translation Km/h 2.5/4.5
 Undercarriage's width mm 1660

ROTAZIONE ROTATION

Velocità di rotazione torretta 8 g/1'
 Brandeggio laterale 90° a sinistra
 Brandeggio laterale 45° a destra
 Raggio minimo di rotazione 1700 mm

Turret speed rotation 8 rpm
 Lateral traverse 90° left
 Lateral traverse 45° right
 Min. rotation range 1700 mm

LAMA REINTERRO FRONTAL BLADE

Dimensioni mm 1680x350
 Altezza massima mm 350
 Profondità massima mm 385

Dimensions mm 1680x350
 Max height mm 350
 Max depth mm 385

RIFORMIMENTI PROVISIONS

Serbatoio gasolio l 49
 Serbatoio olio l 80
 Impianto idraulico (totali) l 120

Diesel tank l 49
 Oil tank l 80
 Hydraulic system (total) l 120

PESO OPERATIVO OPERATING WEIGHT

Peso operativo Kg 3860-3980
 Operating weight Kg 3860-3980

DOTAZIONI STANDARD: benna da mm 700, tettuccio, faro di lavoro, predisposizione impianto martello semplice effetto, doppio effetto, kit attrezzi.

STANDARD EQUIPMENT: bucket mm 700, canopy, working light, hydraulic hammer system, double effect installation, set of tools.

PRESTAZIONI:
 Forza di strappo al dente: Kg 3000
 Forza di scavo: Kg 2500

PERFORMANCES:
 Tooth ripping force: Kg 3000
 Digging force: Kg 2500



HINOWA S.p.a.
 Via Fontana
 37054 NOGARA (VR) ITALIA
 Tel. +39-0442 539100 - Fax +39-0442 539075
 e-mail: hinowa@hinowa.it
 web site: www.hinowa.com

Hinowa

VT 4000



FORTI
e preziosi

Serie VT DIAMANT