

I  
GB



# MINIESCAVATORE DB 10.13

**Massime prestazioni  
al minimo costo!  
*The best performance  
at the lowest price!***

# Hitachi

## 10 VALIDI MOTIVI CHE VI FARANNO APPREZZARE IL MINIESCAVATORE DB 10.13

- 1 Il prezzo più basso di tutti i miniescavatori sul mercato
- 2 Altissima qualità dei materiali impiegati e dei componenti usati
- 3 Le performance più elevate della sua categoria
- 4 Costi di manutenzione e di mantenimento ridottissimi
- 5 Facilità d'uso estrema
- 6 Sicurezza per l'operatore ben superiore ai parametri richiesti dalla normativa
- 7 Carro di grosse dimensioni a garanzia di robustezza, stabilità e potenza con doppia velocità di traslazione
- 8 Motore Honda da 13HP con valvole in testa con cofanatura
- 9 Tettuccio omologato Fops-Tops a quattro montanti smontabile
- 10 L'impianto idraulico è alimentato da tre pompe a ingranaggi e prevede una presa di potenza idraulica ausiliare per l'utilizzo di attrezzature quali: martello demolitore trivella-pinza ecc.

## 10 GOOD REASONS TO BE PLEASED ABOUT THE DB 10.13 MINI EXCAVATOR

- 1 Its price is the lowest on the market as far as mini excavators concerns
- 2 Its materials and components are of a very high quality
- 3 It has the highest performances of its range
- 4 Very low maintenance and use costs
- 5 It is very user friendly
- 6 Safety for the user far above the standard required
- 7 It is equipped with a big tracked undercarriage in order to grant strength, stability and power. This undercarriage features two travel speeds
- 8 It is equipped with a 13 HP Honda petrol motor, with bonnet and overhead (OHV) valves
- 9 Its protection roof is homologated Fops Rops with 4 posts, dismountable
- 10 Its hydraulic system is fed by 3 gear pumps and offers the possibility to fit a hydraulic power takeoff for attachments such as: demolition hammer, auger, pliers etc.



## MINIESCAVATORE DB 10.13

La **compattezza**, con la quale è stato progettato il MINIESCAVATORE DB 10.13, permette di entrare ovunque, il baricentro è molto basso e la macchina è saldamente ancorata al terreno durante le fasi di scavo.

*The **smallness** of the DB 10.13 mini excavator allows it to enter everywhere; the centre of gravity is very low and the machine is firmly anchored to the terrain during the digging phases.*

## OPTIONAL OPTIONS



**BENNE 20-30-40  
60 SENZA DENTI  
20-30 AND  
40CM BUCKETS  
60CM DITCH  
BUCKET**



**TETTUCCIO  
CON CINTURE  
DI SICUREZZA**



**CANOPY  
WITH SAFETY  
BELTS**



**BRACCIO LUNGO  
IMPIANTO  
IDRAULICO  
LONG ARM  
HYDRAULIC  
SYSTEM**



**MARTELLO  
HAMMER**

**TRIVELLA  
AUGER**



**ALLARGAMENTO  
LAMA  
BLADE'S EXTENSIONS**

# MINIESCAVATORE DB 10.13

### MOTORE BENZINA

Marca ..... HONDA  
Tipo ..... GX390  
Cilindri e cilindrata ..... monocilindrico 389cc  
Potenza lorda max ..... 13 cv/9,6kw/@3600rpm  
Regime di taratura ..... 3500 rpm  
Avviamento elettrico (opzionale)..... 12 volt

### DISTRIBUTORE

Marca ..... HYDROCONTROL  
Tipo..... meccanico

### POMPA IDRAULICA

Marca ..... CASAPPA  
Numero e tipo ..... n° 3 ad ingranaggi  
Portata litri minuto ..... 3 x 12 lpm  
Pressione ..... 175 bar

### MOTORIDUTTORE

Marca ..... TRASMITAL  
Tipo ..... orbitale  
Cilindrata ..... 65 cc  
Rapporto di riduzione ..... 1:5,25

### CINGOLATURA

Tendicingolo ..... a grasso  
Marca ..... BRIDGESTONE  
Dimensioni ..... 200 x 96 x 28  
Velocità di traslazione ..... 2/3 km/h  
Rulli per lato ..... 3

### PESO OPERATIVO

(escluso operatore) ..... Kg 920

SERBATOIO BENZINA ..... litri 6,5

### PRESTAZIONI

Forza di strappo max ..... 8385 N (~ 855 Kg)  
Forza di scavo max ..... 5275 N (~ 540 Kg)

### GASOLINE ENGINE

Brand ..... HONDA  
Model ..... GX390  
No.Cylinders and cubic displacement .....  
.....single-cylinder 389cc  
Max. Power ..... 13 hp/9,6kw/3600rpm  
RPM ..... 3500  
Electric starting (optional)..... 12 Volt

### DISTRIBUTOR

Brand ..... HYDROCONTROL  
Model ..... mechanic

### HYDRAULIC PUMP

Brand ..... CASAPPA  
No. and model ..... n.3 by gear  
Capacity l/per minute ..... 3 x 12 lpm  
Pressure ..... 175 bar

### REDUCTION GEAR DRIVE

Brand ..... TRASMITAL  
Model ..... orbital  
Cubic displacement ..... 65 cc  
Ratio ..... 1:5,25

### TRACK

Idler tensioned ..... by grease  
Brand ..... BRIDGESTONE  
Dimensions ..... 200 x 96 x 28  
Translation's speed ..... 2/3 km/h  
Rollers per side ..... 3

### OPERATING WEIGHT

(Without operator) ..... Kg 920

PETROL TANK ..... 6.5 litres

### PERFORMANCES

Max ripping force ..... 8385 N (~ 855 Kg)  
Max digging force ..... 5275 N (~ 540 Kg)

# MINIESCAVATORE DB 10.13

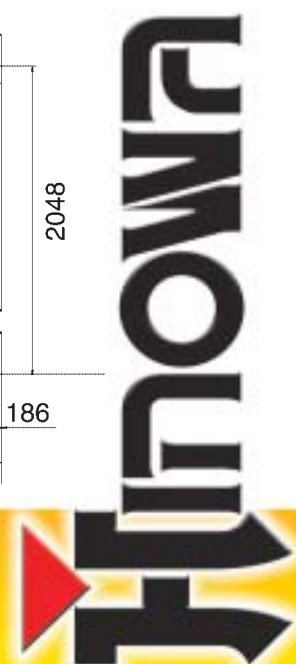
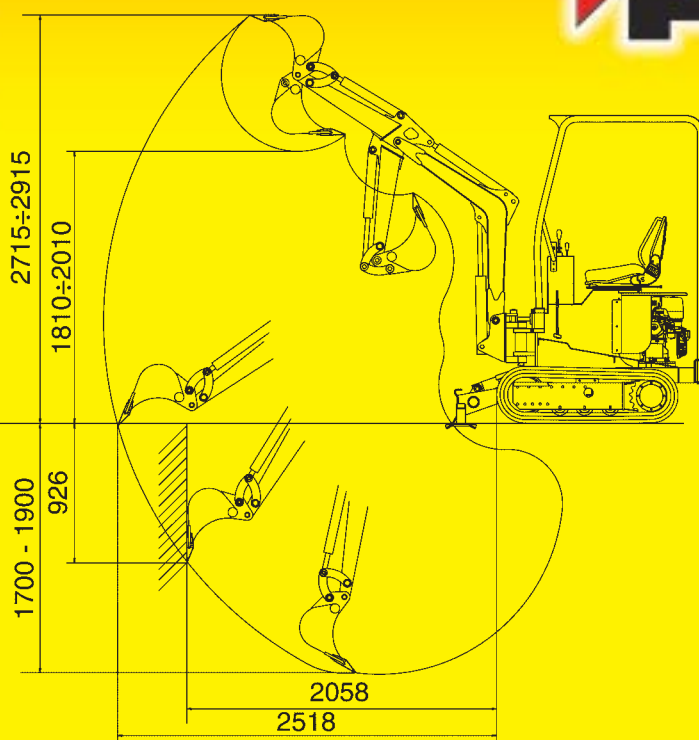
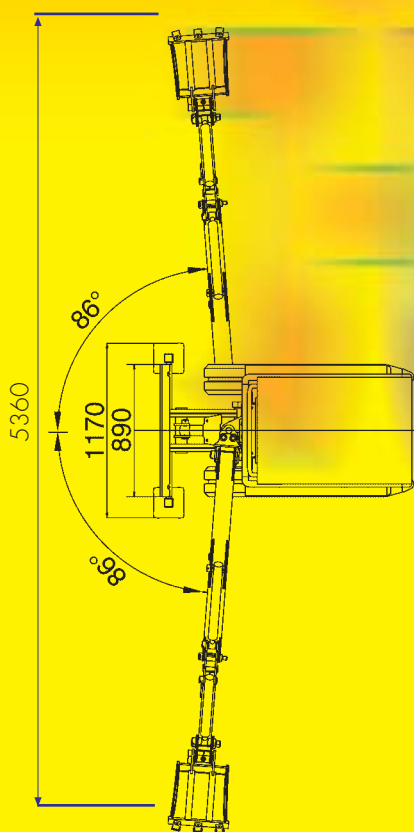
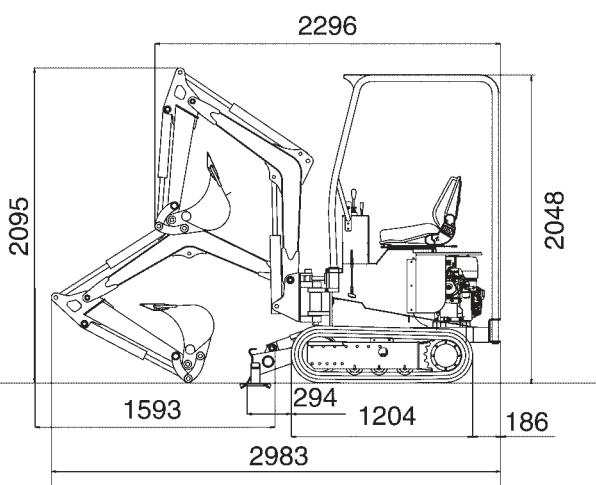
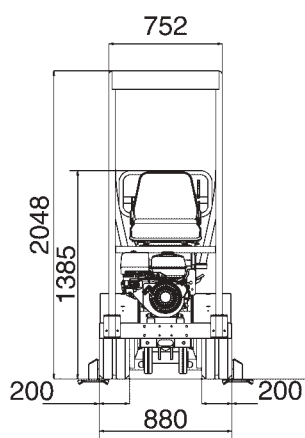



Il **MINIESCAVATORE HINOWA DB10.13** è molto bilanciato. E' in grado di sollevare e trasportare materiali di notevoli dimensioni. La cingolatura molto robusta permette una movimentazione disinvolta su ogni tipo di terreno.

*The **Hinowa DB 10.13** is very well balanced. It can lift and carry material of very big dimensions. The strong track allows an easy handling on every kind of terrain.*

La **LAMA FRONTALE** può essere usata per il reinterro, la movimentazione idraulica e la potente cingolatura rendono l'operazione estremamente facile e veloce.

*The **front blade** can be used for the trench refill operations; the hydraulic handling and the strong track let the operation be extremely easy and quick.*

LA GRANDE FACILITA'  
DI TRASPORTO  
**MINIESCAVATORE  
DB 10.13**

*EASE OF  
TRANSPORTATION*



Il peso contenuto permette di caricare il miniescavatore DB 10.13 su camioncini e pick-up e su carrelli trainati senza oltrepassare la portata ammessa

*The reduced weight allows the mini excavator to be loaded on trucks, pick-up and trailers without exceeding the allowed capacity*



**Hinowa**

**HINOWA SPA**  
via Fontana • 37054 NOGARA Verona - Italy  
tel. +39 0442 539100 fax +39 0442 539075  
[www.hinowa.com](http://www.hinowa.com) • [hinowa@hinowa.it](mailto:hinowa@hinowa.it)

